

LISTED

**A MAJOR CAUSE OF VENT RELATED FIRES  
IS FAILURE TO MAINTAIN  
REQUIRED CLEARANCES (AIR SPACES) TO  
COMBUSTIBLE MATERIALS.**

**IT IS OF THE UTMOST IMPORTANCE THAT  
THIS DOUBLE WALL VENT SYSTEM BE  
INSTALLED ONLY IN ACCORDANCE  
WITH THESE INSTRUCTIONS.**

**PLEASE READ ALL INSTRUCTIONS BEFORE  
BEGINNING YOUR INSTALLATION.  
FAILURE TO INSTALL THIS SYSTEM IN  
ACCORDANCE WITH THESE INSTRUCTIONS WILL  
VOID THE CONDITIONS OF CERTIFICATION AND  
THE MANUFACTURER'S WARRANTY.**

**Tested to Standards  
UL 641  
CAN/ULC-S609  
ULC/ORD-C441**

***Installer: It is of the utmost importance that these UPP instructions are  
left with the homeowner.***

***Homeowner: Keep these instructions and maintenance guide in a safe  
place for future reference.***

**Ultimate Pellet Pipe**

# TABLE OF CONTENTS

TECHNICAL SPECIFICATIONS	
Product Details.....	3
Operating Temperatures.....	3
Framing Dimensions.....	3
Maximum Support Capacity.....	3
APPROVAL LABEL	
Ultimate <i>Pellet Pipe</i> Approval Label.....	3
PRE-INSTALLATION GUIDELINES	
Safety Certification .....	4
Sizes & Applications, Clearances.....	4
Enclosures, Appliance Safety.....	4
Vent Size, Height and Terminations.....	4
Permits, Tools and Equipment.....	5
Rules for Safety.....	5
Gasket and use of Sealant.....	5
General Installation Instructions.....	5
Common Types of Installation and Instructions.....	5
Common Considerations and Requirements.....	6
Rules for Distances from Terminations.....	6
Common Types of Installations.....	7
VENT INSTALLATION	
Adapters, Adjustable Length, Wall Thimble.....	8
Tees, Vacuum cleanout.....	9
Wall Band/Support and Vertical Penetrations.....	9
Ceiling Supports & Support Band.....	10
Attic Insulation Shield, Elbows, Flashings, Vertical Termination Cap.....	11
Horizontal Terminations and Chimney Adapter.....	12
Masonry Adapter.....	13
Insert Installation into Masonry Fireplace.....	13
Painting, Maintenance Requirements.....	13
INFORMATION	
System Parts.....	14
Installation Information.....	15

# Ultimate Pellet Pipe TECHNICAL SPECIFICATIONS

READ ALL INSTRUCTIONS BEFORE BEGINNING YOUR INSTALLATION. FAILURE TO INSTALL THIS SYSTEM IN ACCORDANCE WITH THE INSTRUCTIONS WILL VOID THE CONDITIONS OF CERTIFICATION AND THE MANUFACTURER'S WARRANTY. OUR CHIMNEY SYSTEMS ARE DESIGNED FOR INSTALLATION BY A QUALIFIED PERSON IN ACCORDANCE WITH LOCAL BUILDING CODES. KEEP THESE INSTRUCTIONS IN A SAFE PLACE FOR FUTURE REFERENCE.

**CAUTION: WEAR CUT RESISTANT GLOVES WHILE HANDLING METAL PARTS TO AVOID PERSONAL INJURY. SHARP EDGES OR PROJECTIONS CAN CUT YOU.**



**WARNING**

Failure to follow the installation instructions could cause FIRE, CARBON MONOXIDE POISONING, OR DEATH. If you are unsure of installation requirements, call the telephone number listed on these instructions, or visit our website [www.Ultimatepelletpipe.com](http://www.Ultimatepelletpipe.com).

**Table 1 TECHNICAL SPECIFICATIONS**

<b>Materials:</b>		Exterior (casing): .018" Galvalume Steel		Insulation: .375" Air Space	
		Interior Flue: .016" 304 Stainless Steel		Gasket: Silicone	
<b>Diameters</b>			<b>Installed Length</b>		
Inside Diameter (I.D.)	3"	4"	Minus 1.75" for the overlap		
Outside Diameter (O.D.)	3.75"	4.75"			
Weight/Foot (lb/ft.)	1.12	1.68			
<b>Rough Framing Opening - 3" and 4"</b>		<b>Product Height</b>		<b>Maximum Support Capacity</b>	
Ceiling Support (CSB)	7" X 7" (Except for CCS)	10.5"		Ceiling Support (CSB, FSC)	30 Feet
Firestop Ceiling Support (FSC)		2"		Cathedral Support (CCS)	30 Feet
Cathedral Support (CCS) <i>(Frame as to create a rectangular framed opening suitable to accept the CCS)</i>		14"		Wall Band / Support (WB)	Every 8 Feet
Wall Thimble (WB)		5" min to 9" max		<b>Clearances</b>	
Attic Insulation Shield (AIS)				12.5" min to 23.5" max	
		<b>Flue Gas Temperatures</b>			
				Maximum Operating Temperatures	570°F / 300°C

**Sample of Approval Label**

UltimatePelletPipe™

823007

E/28/15 MODEL UPP MODELE



Type L Low Temperature Venting System. LISTED UL641, CAN/ULC-S609, ULC/ORD-C441. Minimum Clearance 1" (25mm) air space to combustible materials and building materials. Install only in accordance with the manufacturer's instructions. Suitable only for connection to listed wood, pellet, gas, and oil appliances producing flue gases between 212°F (100°C) & 570°F (300°C). Do not connect to any other type of appliance. For interior & exterior use.

Systèmes de ventilation de basse température de type L. Testés pour les appareils à bois, à gaz, à pétrole et à huile. Maintenir un espace de dégagement d'au moins 1 po (25mm) des matériaux combustibles et de l'isolant du bâtiment. Installez uniquement selon les directives du fabricant. Convient uniquement pour l'installation avec les appareils de granule à bois, huile et gaz, produisant des températures de combustion entre 212°F (100°C) et 570°F (300°C). Ne pas raccorder à tout autre type d'appareil. Utilisable à l'intérieur ou à l'extérieur.

TF

ADJUSTABLE LENGTH 12"  
MADE IN USA

LONGUEUR AJUSTABLE 12PO  
FABRIQUE AU ETATS-UNIS



2



UP  
HAUT

# PRE-INSTALLATION GUIDELINES

## 1. MODEL UPP SAFETY CERTIFICATION

Model UPP has been tested and listed by Underwriters Laboratories, Inc. in accordance with UL641, the Standard for Type L Low Temperature Venting Systems, in addition to certain other applicable requirements from UL103, the Standard for Residential Type and Building Heating Appliance Chimneys. Model UPP has also been tested and listed to Canadian Standards ULC-S609 for Low Temperature Vents Type L and ULC/ORD-C441 for Pellet Vents. Model UPP is approved for venting oil fired appliances listed for use with Type L Vent and Pellet stoves that do not exceed flue temperatures of 570°F (300°C).

Table 1 found on page 3 provides technical specifications such as maximum support capacity, clearances and the proper framing dimensions, which in turn define the proper clearance and maximum operating temperatures. Wherever these instructions illustrate the use of a required spacer, thimble or firestop, the purpose of the part is to maintain and assure the proper clearance.

## 2. SIZES AND APPLICATIONS

Model UPP is manufactured in 3" and 4" I.D. sizes.

UPP installed in accordance with these instructions comply with National Safety Standards such as NFPA 211 in the US and CSA-B365 in Canada.

The Model UPP System may be used for venting gas or oil fired appliances listed for use with Type L-Vent in addition to Listed pellet burning appliances.

If you choose to have your product professionally installed, we recommend UPP be installed by professionals who are certified in the USA by NFI (National Fireplace Institute) or in Canada by WETT (Wood Energy Technology Transfer).

Contact your local building authority and/or fire officials for permits, restrictions and installation inspections. You may also wish to contact your home insurance representative.

## 3. MINIMUM CLEARANCE--AIRSPACE ONLY

All Model UPP flue gas carrying parts are marked with clearance information as follows:

**MAINTAIN MINIMUM 1" (25mm) AIRSPACE CLEARANCE TO COMBUSTIBLES** in the U.S. and in Canada. Do not fill this required airspace with insulation.

"Combustible" materials include framing lumber, drywall, plaster, plywood, paneling, lath, furniture, curtains, electrical wiring, building insulation or any other building materials.

In addition to the airspace clearance specification, each section of vent is marked with an "UP" arrow indicating the intended direction of flow (i.e. end which should be oriented AWAY from the appliance). Auxiliary parts such as Ceiling Support, Firestop Ceiling Support, Trim Plate, Flashings and Wall Thimble outer shields are intended to be attached directly to the framing or to ceilings, floors, or walls in accordance with their respective instructions. These parts, which are installed in contact with wood or other combustibles, are designed and tested to assure that they do not overheat at points of contact.

Remember that clearance requirement is AIRSPACE ONLY. Never fill any required clearance space with insulation or any other materials.

Do not mix and match with other manufacturer's products.

## 4. ENCLOSURES

The vent system should be enclosed in occupied areas, closets, storage rooms, and accessible attics. Enclosures may be built of ordinary drywall or plywood at the required minimum AIRSPACE CLEARANCE (See Table 1). There are no special parts to maintain clearance to inside surfaces of walls or enclosures. Therefore, the vent installer should take all necessary precautions to assure that this minimum airspace is maintained.

In attics, it is important to extend the Attic Insulation Shield to the maximum height possible. This will prevent any contact between the insulation and the vent when loose fill insulation such as cellulose is used. This will also prevent contact with insulation added in the future.

NOTE - CELLULOSE type insulation may be composed of old newspapers and other cellulose materials which are very susceptible to ignition of a fire.

A vent system enclosure is also recommended for any exterior systems and portions extending through unheated areas. This enclosure is helpful in reducing internal condensation, residual buildup from products of combustion and metal deterioration. Also the enclosure, by protecting the vent from cold outdoor temperatures, may improve draft and appliance operation. At the upper end of an outdoor enclosure the vent system should be finished off with a UPP Flashing, Storm Collar and Termination Cap as described elsewhere in these instructions.

Regardless of the benefits of the exterior enclosure, better vent and appliance operation will be obtained if the vent is located entirely inside the heated portion of the building (except of course for the part above the roof).

## 5. YOUR CHOICE OF HEATING APPLIANCE

There are three important rules for selecting a gas or pellet burning appliance.

FIRST: Look for a label or nameplate attached to the appliance which bears the mark of a recognized Testing Laboratory such as WH, ITS, UL, ULC, CSA or OMNI.

SECOND: Don't buy an appliance which is larger than necessary.

THIRD: Look or ask for complete installation, operating and maintenance instructions for the appliance. If you can't get these, buy one that includes all these very important details.

## 6. APPLIANCE SAFETY

Be sure to follow all details of the instructions provided with your appliance. Especially note and follow recommended installation clearances and operating instructions.

## 7. VENT SIZE, HEIGHT AND TERMINATION

Before beginning installation of the vent system, be sure the selected size is adequate for the appliance and the selected height of the Model UPP termination is sufficient to conform to building code requirements and the termination height guidelines given elsewhere in these instructions. **The vent should be sized according to the appliance manufacturer's instructions.**

# PRE-INSTALLATION GUIDELINES

## 8. PERMITS, TOOLS AND EQUIPMENT YOU MAY NEED

If you have not already obtained the necessary permits for the installation, do so before proceeding further.

Accumulate all the parts you plan to use along with the tools, equipment and supplies you may need to complete your work.

These may include:

Eye Protection	Hammer
Gloves	Assorted Nails
Tape Measure	Assorted Wood Screws
Marking Pencil	Ladder
Circular Saw	Plumb Bob
Screwdriver	Razor Knife
Extension Cord	Level
Hand Saw	Pliers
Square	Electric Drill
1/8" or 3/32" drill bit	Caulking Gun
"Stud Sensor" or similar device (for locating framing)	
Keyhole, Jig, Sabre or Reciprocating Saw	
High Temperature silicone sealant (450°F)	
Non-hardening waterproof mastic or caulking	

## 9. RULES FOR SAFETY DURING INSTALLATION

A. Wear safety glasses when sawing, nailing, or using other power tools.

B. Wear gloves when handling sheet metal parts with sharp edges.

C. Be sure all electrical tools are properly grounded.

D. Be very careful when cutting openings and working in the area where electrical wiring is located. Wiring should be secured at least 3" away from the outer surface of any vent section. If wiring must be relocated, have this done by a qualified electrician.

E. Ladders, where necessary, should be in good condition and set upon a firm, level surface.

## 10. A NOTE ABOUT PRODUCTS OF COMBUSTION FROM PELLET BURNING APPLIANCES

One of the most common, visible products of combustion from many pellet burning appliances is a fine, powdery dust which may tend to accumulate near the outlet of the vent and/or at the joints within the vent. While this material is believed to be non-combustible, it should not be permitted to accumulate within the system since significant accumulation could begin to affect both the vent system's ability to function properly and the heating appliance operation. Accordingly it is recommended that the system be inspected periodically for the build-up and cleaned if necessary. In order to help minimize the accumulation of this powder within the system, each vent section is provided with a hi-temperature silicone gasket within the annulus of the male end. This gasket helps minimize air movement through joints, thereby enhancing the draft through the vent system and minimizing the powder accumulation.

## 11. GASKET AND USE OF SEALANTS

Model UPP does not require additional sealant due to its unique high temperature silicone gasket found on the inside of the inner pipe sections, Adjustable Length, Elbows, . This gasket seals the pipe sections as they are connected together. If this gasket is missing, contact your dealer so a gasket can be sent to you.

Model UPP does not require additional sealant to be used at the pipe joints, but in some instances sealant will be required. You will require a high temperature silicone sealant (450°F/232°C) for the following connections: All Appliance Adapters or any other components when connecting to the appliance flue outlet.

## 12. VENTING MORE THAN ONE APPLIANCE

In certain instances more than one gas or oil fired appliance may be connected to the same vent system. Be sure to follow the appliance manufacturer's recommendations and local fire and building code requirements if this is planned. UNDER NO CIRCUMSTANCES should a pellet burning appliance be connected into the same vent system as any other type of appliance.

## 13. SUPPORT

Model UPP vent system must be securely supported. Lateral runs are to be supported at least every 5 feet. When offsets are necessary, adequate support above and below the offset is required. It is permissible to secure the elbows forming an offset with a minimum of two ¼" sheet metal screws at the joint being careful not to drill through the stainless steel inner wall of the vent. Pre-drill a 3/32" hole approximately 3/8" above the line of the joint then install the screws.

Vertical runs are normally supported by one of the following: Ceiling Support (CSB), Firestop Ceiling Support (FCS) or a Cathedral Ceiling Support (CCS). A Through-The-Wall installation will be supported by the Wall Band/Support (WB) placed at 8' intervals with the first one installed 6" to 8" above the Tee.

## 14. GENERAL INSTALLATION INSTRUCTIONS

### VENT SECTION INTERCONNECTION

Ensure that the silicone gasket is firmly placed in its groove before attempting to assemble the lengths. To facilitate ease of engagement use soapy water on the silicone gasket prior to assembly. Use a dielectric grease to moisten the silicone gasket (sold separately). Do not use a petroleum-based lubricant. Each flue gas carrying section of Model UPP is designed with a male and female end. To join sections, simply insert the formed, gasketed male end between the walls of the open, female end. Push and gently twist the pipes until the dimples on the male end are covered and the pipe is fully seated against the ridge on the adjoining pipe. Using a flat head screwdriver, push the Lock-Tab in against the pipe underneath it. This will keep the joints from becoming separated (see figure 7).

### COMMON TYPES OF INSTALLATIONS

Table 2 on page 7 shows six common types of installations of the Model UPP vent system. These figures provide a reference for reviewing common applications for the various system parts.

## 15. INSTRUCTIONS FOR INSTALLING VENT

1. Refer to "Common Considerations" section on page 6 for a list of items that should be taken into consideration before beginning any installation.

2. Locate the appliance as per manufacturers' recommendations, making sure to maintain specified clearances to combustibles.

3. Attach Appliance Adapter (AA) as per section on "Appliance Adapter" (See Figs 1-6).

4. If the vent planning was to include a vertical rise, a Tee Section (T) can be used to turn the vent vertical. See Figs 1, 2, 4, 5, 6 and section on Tees. Position tee so that it is vertical, and the cleanout tee cap is at the bottom. Attach tee to vent.

5. Connect additional pipe sections to route the system out of the building.

See "Adjustable Length" section for situations where a non-standard length of pipe is necessary.

6. Refer to "Wall Band / Support" (WB) section for instructions for providing support for the vent system for Through-Wall application (see Figs. 4-6).

7. For vertical applications see section on "Vertical Applications" for proper installation (see also Figs 1 to 4).

# COMMON CONSIDERATIONS AND INSTALLATION REQUIREMENTS

8. For Through-The-Wall Applications, see section on “Wall Thimble” for proper installation (see Figs 4-6).

9. If a Tee and a Wall Band/Support was included in the planning, see section entitled “Tee and Wall Band / Support” for proper installation (see Figs 4-6).

10. When terminating vertically through the roof, see sections on “Roof Flashing”, “Storm Collar”, & “Vertical Termination Cap” (see Figs 1, 2, 3 and 5).

11. When terminating through a wall, See section on “Horizontal Termination Cap” (see Figs. 4 and 6).

## 16. COMMON CONSIDERATIONS

The following comments apply to all types of installations.

1. Before beginning any installation, select the desired location for the appliance, being sure to maintain the appliance manufacturer's specified minimum clearances. Try to minimize the amount of work by choosing a location where framing members in the walls and floors will not interfere with the intended vent location or the required airspace clearances.

2. Where possible, minimize the length and total number and degree of offsets in your vent system in order to permit the system to vent optimally. Use of too many offsets may result in poor draft and may affect the performance of the appliance. Ensure you verify the appliance manufacturer's installation instructions for any restrictions and the equivalent vent length.

3. Throughout these instructions, where preparation of an opening for passage of Model UPP through walls is referenced, we recommend cutting and FRAMING the opening to the appropriate size. While framing is not necessary in all cases, it is recommended in order to maintain the integrity of the structure and provide sufficient anchoring for fasteners, especially where support assemblies will be installed.

4. Framing of the opening is required for all vertical penetrations where a firestop is specified, in order to provide adequate fire-stopping. Framing materials needs to be the same material thickness as the ceiling or floor joist.

5. Proper planning for your Model UPP vent installation will result in greater safety, efficiency and convenience, saving time and money.

6. Use ONLY Model UPP listed parts.

7. DO NOT INSTALL damaged parts.

8. PERMITS are required in most areas. Contact your local building code and/ or fire officials regarding permits, restrictions, and installation inspections in your area BEFORE you begin your installation.

## 17. YOUR SPECIFIC INSTALLATION REQUIREMENTS

Now that you have an overview of the system parts and optional types of installations, you are ready to plan an installation to meet your specific needs. We suggest proceeding as follows:

1. Carefully review your options for the installation and select a tentative location and vent system configuration. This may be similar to one or a combination of Figs. 1 through 6.

2. Review the appliance installation instructions and determine whether the location and vent configuration you selected are suitable, convenient and attainable. Plan to incorporate parts which will facilitate inspection and cleaning.

3. After you are satisfied with the location and configuration, plan the exact layout, identifying all component parts, sizes and dimensions you will need to complete the installation. Check to insure that you have access to all parts and accessories you will need.

4. If space permits, install the appliance and begin installing the vent system directly at the appliance flue collar and work toward the

termination. If space does not permit, plan the exact location of your appliance and determine the exact lengths of system components which will extend between your appliance flue collar and the wall or ceiling you will penetrate. Begin the installation of the vent system at this location and work in each direction. Complete the installation by moving the appliance into position and making the final connection between the appliance flue collar and the Appliance Adapter.

5. As necessary, refer to these detailed instructions for installation of the various component parts, being careful to maintain the required clearances to combustible construction.

6. Upon completion of your installation, check to see the exterior portions of the vent systems are properly installed and protected from weather. Check to see that all system components are securely attached and installed in accordance with these instructions.

7. Install any necessary enclosures in occupied areas and in attics to help insure the system is not damaged and the required airspace clearance to combustibles is maintained (see “Enclosures”).

## 18. RULES FOR DISTANCES FROM HORIZONTAL EXIT TERMINATIONS

Before beginning any installation which will result in a vent cap being installed adjacent to the side of a structure:

1. Check to confirm that local fire and safety codes permit this type of installation. If so, install per code requirements.

### When installed in the USA:

2. In the absence of overriding local requirements, use the following National Fire Protection Association Standard 211 guidelines for distances from the exit termination to doors, windows, air inlets, etc.: The exit terminal of a mechanical draft system, other than a direct vent appliance (sealed combustion system appliance), the Termination shall be located in accordance with the following:

A. Not less than 3 ft. (0.91 m) above any forced air inlet located within 10 ft. (3m).

B. Not less than 4 ft. (1.2m) below, 4 ft. (1.2m) horizontally from, or 1 ft. (305mm) above any door, window or gravity inlet into any building, and

C. Not less than 2 ft. (0.6m) from adjacent building and not less than 7 ft. (2.1m) above grade when located adjacent to public walkways.

### When installed in Canada:

3. For a Horizontal Termination ULC/ORD-C441 has the following restrictions:

A. Vent Length must not exceed 1200 mm (48”). The Termination shall not be located:

B. Within 1.8m (6 ft) of a mechanical air supply inlet to a building;

C. Above a gas meter regulator within 900 mm (36”) horizontally of vertical centre of the regulator;

D. Within 1.8m (6 ft) of a gas service regulator vent outlet;

E. Less than 300 mm (12”) above grade;

F. Within 1 m (3 ft) of a building opening (windows and doors) or air inlet of another appliance;

G. Not less than 2 ft. (0.6m) from adjacent building and not less than 7 ft. (2.1m) above grade when located adjacent to public walkways.

# TABLE 2 - COMMON TYPES OF INSTALLATIONS

**Fig 1 - Interior Vertical - Ceiling Support**

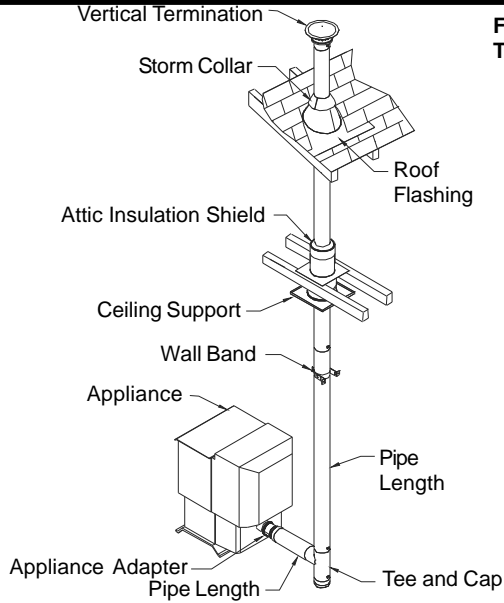

**Fig 4 - Interior Up & Out - Through-Wall**

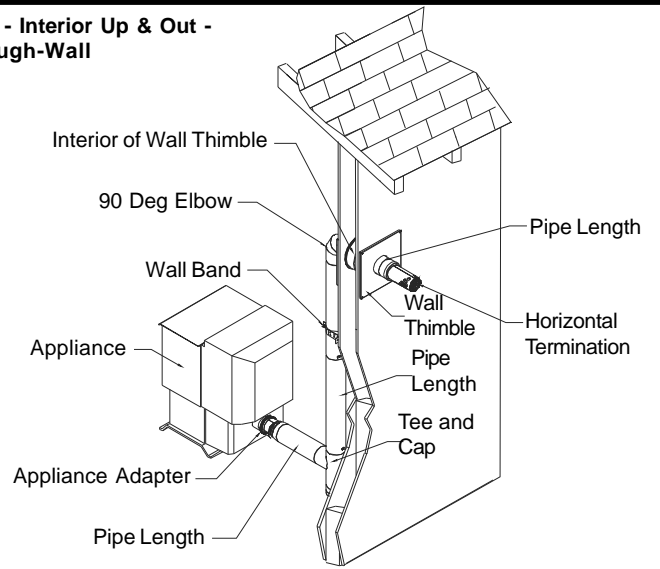

**Fig 2 - Interior Vertical - Cathedral Ceiling Support**

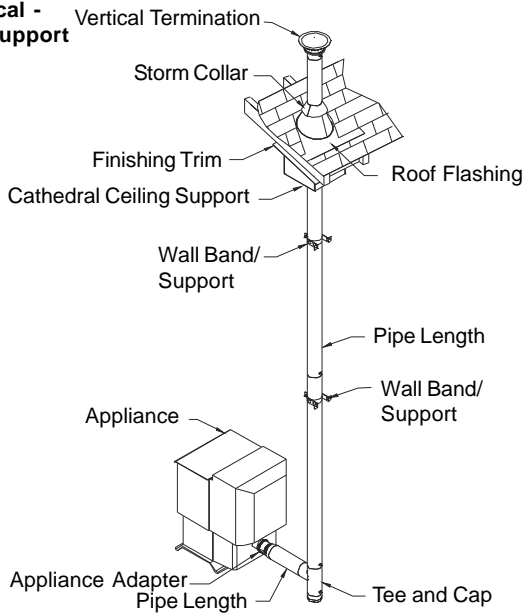

**Fig 5 - Exterior Through Wall - Vertical**

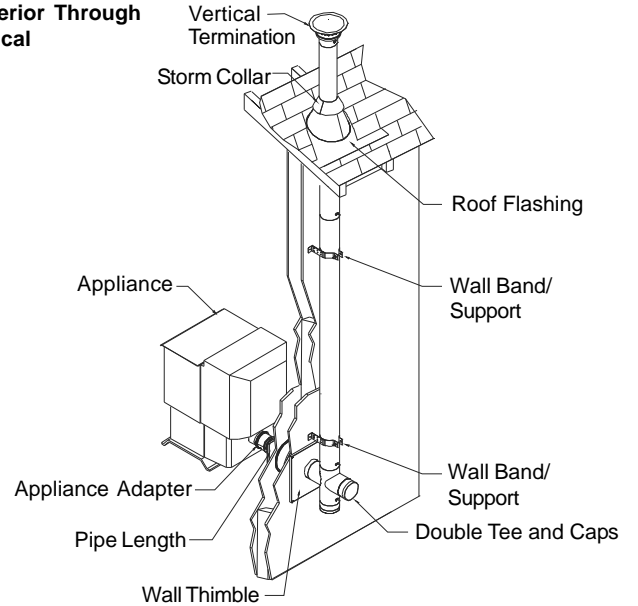

**Fig 3 - Interior - Top Vertical**

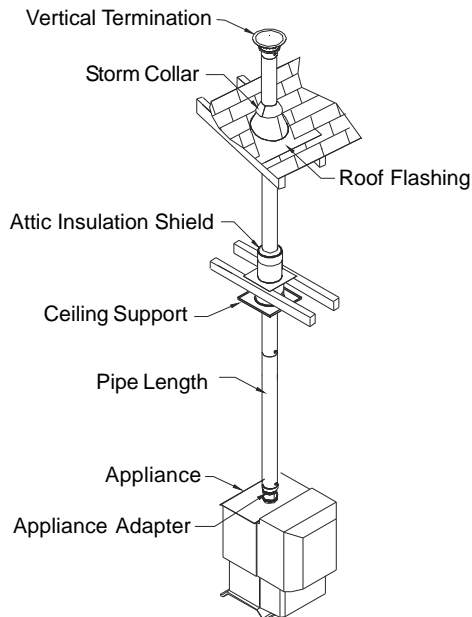

**Fig 6 - Exterior Side Wall - Through Wall**

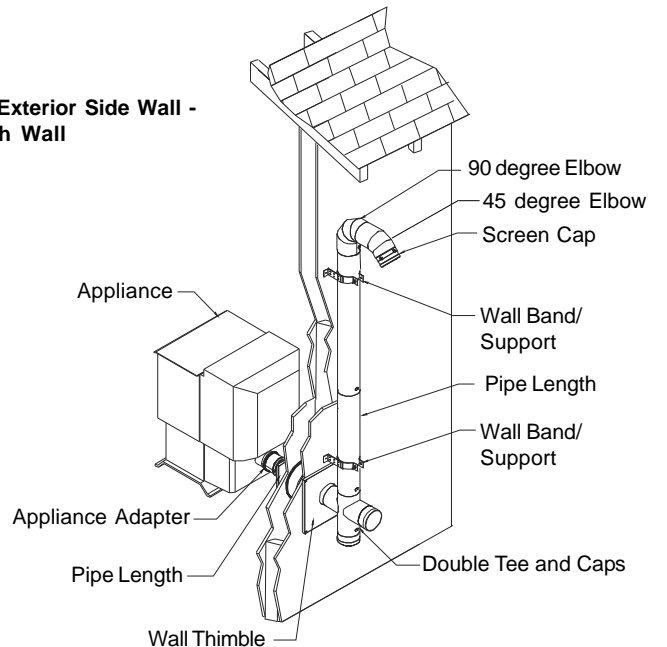

# APPLIANCE ADAPTERS, ADJUSTABLE LENGTH, WALL THIMBLE

## 19. PIPE JOINT CONNECTION

To join sections, simply insert the formed, gasketed male end between the walls of the open, female end. To facilitate ease of engagement use dielectric grease (sold separately) on the silicone gasket prior to assembly. Push and gently twist the pipes until the dimples on the male end are covered and the pipe is fully seated against the ridge on the adjoining pipe. Using a flat head screwdriver, push the Lock-Tab in against the pipe into the Lock-Tab channel. This will keep the joints from becoming separated (see figure 7). If additional securement is desired, one or more, maximum 1/4" long sheet metal screws may be used at the joints. Being careful not to drill through the stainless steel inner wall of the vent, first drill a 3/32" hole approximately 3/8" above the line of the joint then install the screw(s).

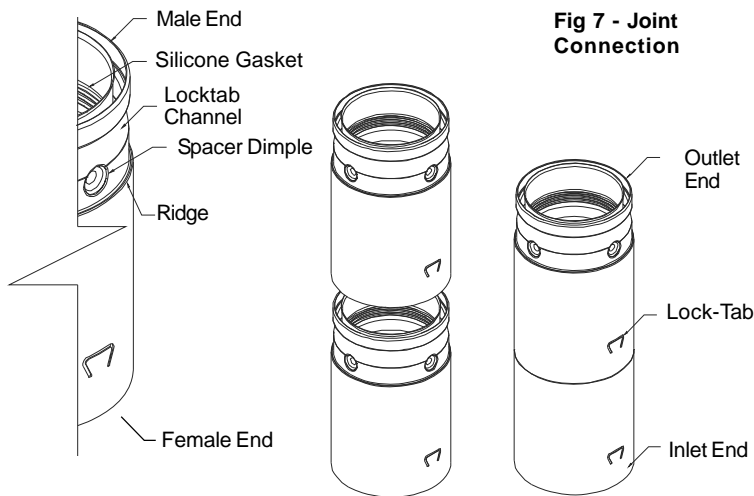

## 20. COMMON VENT SYSTEM PARTS AND THEIR INSTALLATION

### APPLIANCE ADAPTERS (UPP-AA, UPP-HAA1/2, UPP-DTA)

Different Appliance Adapters are used to connect the flue collar of the appliance to Model UPP vent system (see Fig. 8). UPP lengths and components are available in black or unpainted. The Appliance Adapter (AA) has two adjustable hose clamps on the inlet end to connect to the flue collar without the use of supplemental screws. Apply high temperature silicone sealant to the flue collar and slide the Adapter over the flue collar. Tighten the hose clamps, sealing the Adapter to the appliance. The Harman Appliance Adapters come in 2 styles; one is an outside fit over the flue collar (HAA1) and the other is an inside fit into the flue collar (HAA2). High temperature silicone is also needed. Also available is an Adapter to connect to our Direct-Temp for Pellet Vent system. See instructions supplied with DT for Pellet.

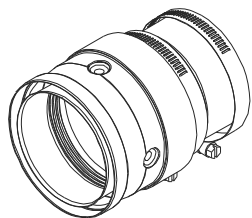

**Fig 8 - Appliance Adapter (AA)**

### ADJUSTABLE LENGTH (UPP-AJ12)

The Adjustable Length is designed for a fixed length to telescoped over it in order to create an assembly of specific length (see Figs. 9a & 9b). It is adjustable from 3/4" to 9-1/4". The Adjustable Length may be used in a vertical, horizontal or sloped configurations. It can also be used on any components.

### To install:

Install the Adjustable Length on top of a straight section below and engage the Lock-Tab. Slide a straight section (any length) over the Adjustable length until the desired length is achieved. Note - the Lock-Tab will not be engaged on this length. Carefully drill three (3) 3/32" diameter holes through the outer casing of the straight section and the Adjustable Length (see Figure 9b), approximately 1/2" from the bottom of the chosen length. Take care not to pierce the inner liner. Use three (3) 1/4" Length sheet metal screws to secure the straight section to the Adjustable Length. Note - The Adjustable Length is commonly used in conjunction with a straight section and the appliance adapter in order to attain a specific length of vent for adapting the system to a specific placement of the appliance.

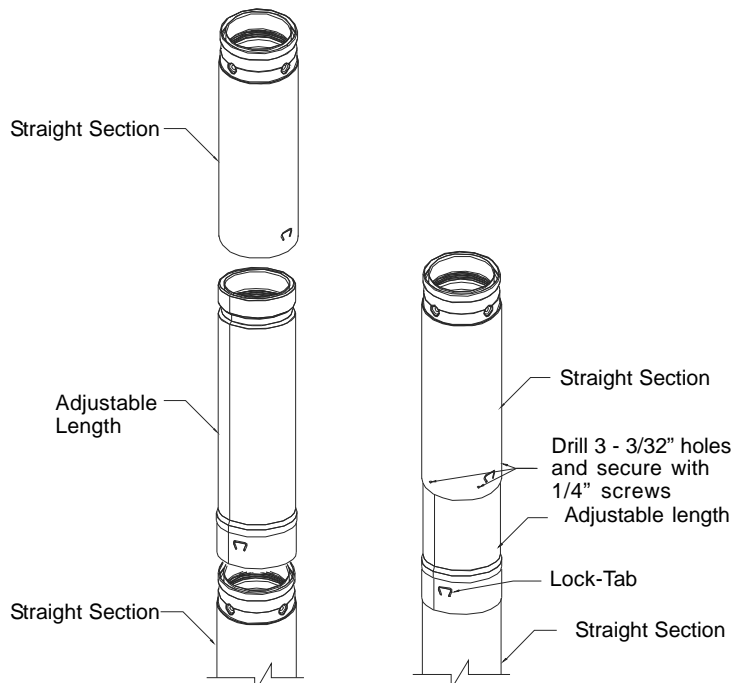

**Fig 9a - Adjustable Length and Straight Lengths**

**Fig 9b - Adjustable Length Assembly to desired height**

### WALL THIMBLE (UPP-WTB)

A Wall Thimble (WTB) must be used for all through-the-wall installations involving combustible construction. The Wall Thimble is designed to accommodate wall thicknesses of 4.5" to 8.5" and may be installed in direct contact with combustible framing, insulation and other materials (see Fig. 10). See Table 1 for framing requirements.

NOTE: The Thimble is shipped in the fully engaged position. Prior to installation, you must disengage the thimble halves.

### To Install:

After preparing the proper sized opening (See Table 1), insert the two halves of the Wall Thimble from opposite sides of the wall and secure to wall with appropriate fasteners (supplied with 4 #8 x 2" panhead black wood screws for interior only). Seal the exterior portion of the Wall Thimble with a waterproof sealant. The thimble is now installed

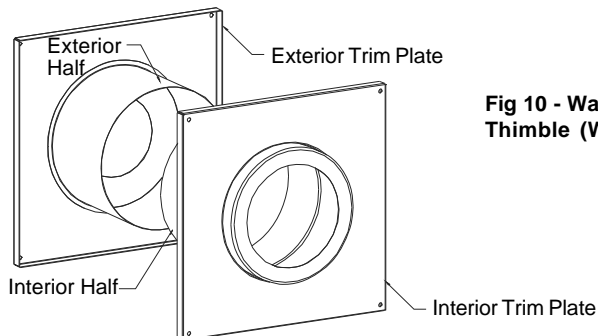

**Fig 10 - Wall Thimble (WTB)**



# TEES AND WALL BAND / SUPPORT

and ready to receive a section of vent. Slide vent through Wall Thimble. You can also seal the gap between the vent and Wall Thimble with sealant.

**NOTE:** If immediately terminating, the horizontal portion of the system beyond the vertical wall must be 6" minimum of vent length before adding the Horizontal Termination.

**NOTE:** It is permissible to add Universal Insulation Shielding (SUSI) to reduce cold air infiltration into the dwelling. See instructions supplied with the Universal Insulation Shielding.

When the combustible wall thickness exceeds the telescoping range of the Wall Thimble, it is permissible to field fabricate a metal sleeve extension.

- 1) The sleeve extension must be of a galvanized sheet metal with a minimum of 26 gauge thickness.
- 2) The sleeve extension must overlap a minimum of one inch (1") over the outer shield and be secured with at least 3 rivets or sheet metal screws.

## TEES (UPP-T, UPP-DT, UPP-TA, UPP-IT)

A variety of Tee sections are designed for use in changing the orientation of the vent from horizontal to vertical and to make cleaning of the system easier than if a 90 deg elbow is used. All tees are provided with a cap on the bottom (UPP-TC) and on one side (UPP-DT, only) held in place with Lock-Tab.

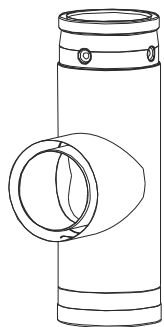

**Tee (T)**  
Fig 11

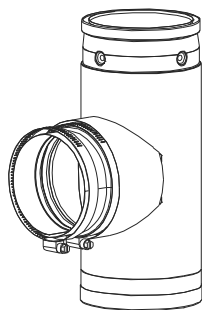

**Tee with Appliance Adapter (TA)**  
Fig 12

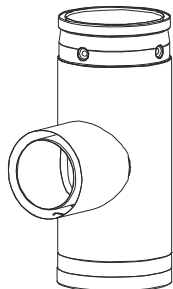

**Increaser Tee (IT)**  
Fig 13

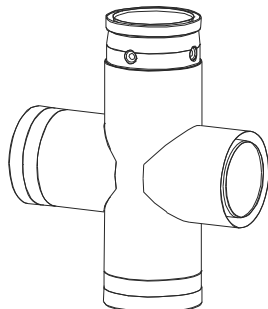

**Double Tee (DT)**  
Fig 14

### To install:

Depending upon the particular installation, the tee is simply suspended behind the appliance and supported by a combination of the appliance and a Wall Band/Support from above (see Figs. 11, 12, 13 or 14). In either case, common sections of vent are attached to the tee inlet and outlet by simply inserting the mating ends until fully seated and the Lock-Tab engaged.

## VACUUM CLEANOUT (UPP-VCC)

A Vacuum Cleanout Cap (Fig 15) can be installed in place of a standard Tee Cap to facilitate future maintenance and cleaning of the system by safely removing ash with no mess.

### To install:

If present, remove existing tee cap. Position VCC so the cleanout fitting will be accessible once installed. Apply high temperature sealant to the engaging surface of the VCC so an air tight seal will be formed once installed. Insert cap into base of tee. Secure VCC by running a #8 x 1/2" self-tapping screw (not supplied) through the outer casing on the lower side of the tee and into the VCC. Pre-drilling is recommended with a 3/32 drill bit.

### To Clean:

Unscrew the fitting at the end of the VCC nozzle. Mate a hose from a Shop Vac or similar vacuum to the VCC nozzle and vacuum out any ash that has collected in the tee. When cleaning is complete, replace the cap fitting by screwing it back on to the end of the cleanout nozzle.

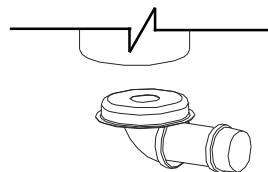

**Fig 15 - Vacuum Cleanout Cap (VCC)**

## WALL BAND / SUPPORT (UPP-WB)

The combination Wall Band/Support is designed to provide both lateral and vertical support for a vent system, which is installed adjacent to a wall. In addition, when properly installed, they provide for the required clearance from the wall and adjust up to 3". The first UPP-WB should be installed 6" to 8" above a tee, additional UPP-WB assemblies should be used at maximum of 8' intervals as the vent system is routed up the wall. Wall Bands/Supports may be installed as the individual sections are being installed or they may be pre-installed, centered over a projected center line of the vent system on the wall of the structure.

### To Install:

(Refer to Fig. 16) - After properly locating the Wall Band/Support on the wall, simply attach the bracket to the wall using suitable fasteners. A pipe section may be inserted within the collar either before or after attachment to the wall. In either case, be sure adjacent vent sections are properly joined together, then simply tighten screw/nut assembly on collar until collar tightly secures vent section in place.

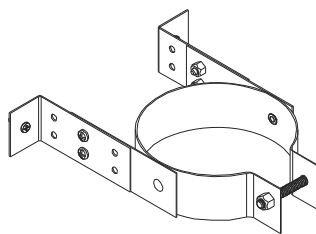

**Fig 16 - Wall Band / Support (WB)**

## VERTICAL PENETRATIONS:

### CEILING SUPPORT (UPP-CSB)

A Ceiling Support (CSB) must be installed where the vent passes through a ceiling or floor joist. The CSB provides vertical support for the vent system and maintains the minimum 1" clearance to combustible materials. A Support Band is also included. The Ceiling Support provides a finished look to the penetration. The overall height of the CSB is 10-1/2".

# CEILING SUPPORTS AND SUPPORT BAND

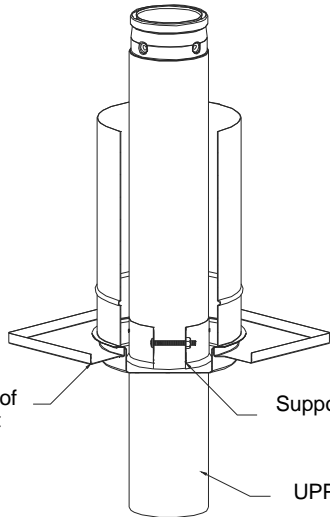

**Fig 17 - Cut-Out of Ceiling Support (CSB)**

**To install:**

Determine the location where the vent will pass through the ceiling. Cut and frame a square opening in the ceiling for support as specified in Table 1. From below insert into the opening and secure the base plate to the framing through the holes provided with four #8 x 2" panhead black wood screws (supplied), see Fig.17. See Support Band section to complete the installation.

NOTE: When an attic space is immediately above a Ceiling Support and interferes with the Attic Insulation Shield, trim the support down flush to the top of the ceiling joist as it must cover ceiling joist depth.

**FIRESTOP CEILING SUPPORT (UPP-FCS)**

The Firestop Ceiling Support (FCS) must be installed where the vent passes through a ceiling or floor joist. The FCS provides vertical support for the vent system and maintains the minimum 1" clearance to combustible materials. A Support Band is also included. The overall height of the FCS is 2". See Fig. 18.

If the location where the vent passes through the ceiling is visible, a Trim Plate (TP) may be desired in order to provide a finished look to the penetration.

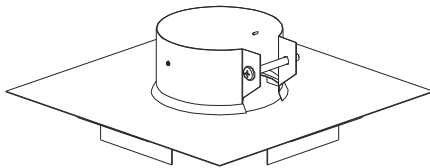

**Fig 18 - Firestop Ceiling Support (FCS)**

**To install:**

Determine the location where the vent will pass through the ceiling. Cut and frame a square opening in the ceiling for support as specified in Table 1. From above insert the FCS into the framed opening and secure the base plate to the framing through the holes provided with four #8 x 1-1/2" panhead black wood screws (supplied). If installing a Trim Plate (TP), center the TP on the ceiling (bottom side) of the opening and secure to the framing members using appropriate fasteners such as with four (4) #8 x 1-1/2" panhead black wood screws (not included). See Support Band section to complete the installation.

NOTE: Do not use the Firestop Ceiling Support if an attic space is immediately above as it would interfere with the Attic Insulation Shield.

**CATHEDRAL CEILING SUPPORT (UPP-CCS)**

The Cathedral Ceiling Support (CCS) may be used in pitched or flat ceiling installations. A Support Band and a decorative two part square Trim Plate is also included. The overall height of the CCS is 14".

**To Install:**

Determine the location where the vent will pass through the ceiling. Cut and frame a rectangular opening in the ceiling for support as

specified in Table 1. From below insert the Cathedral Ceiling Support through the framed opening (end with round opening into the room). Ensure the Cathedral Ceiling Support is level and plumb prior to marking the roof outline on the side of the box. Using tin snips, trim off the excess material at the marked line. You can also cut along the corners of the open end of the box such that the sides can be folded down over the top of the framed opening. Secure to framing for support with eight #8 x 1-1/2" wood screws (supplied) or nail the folded sides to the top of the framing. See Support Band section to complete the installation. NOTE: In a flat ceiling application, when an attic space is immediately above a Cathedral Ceiling Support and would interfere with the Attic Insulation Shield, trim it down flush to the top of the ceiling joist as it must cover ceiling joist depth.

A two-part square Trim Plate is provided to give a finished look once installed. Simply fit the two halves of the Trim Plate around the Cathedral Ceiling Support Box hanging below the ceiling (overlapping if necessary) and screw them to the ceiling (see Fig.19).

NOTE: It is permissible to add Universal Insulation Shielding (SUSI) to reduce cold air infiltration into the dwelling. See instructions supplied with the Universal Insulation Shielding.

**Fig 19 - Cathedral Ceiling Support (CCS)**

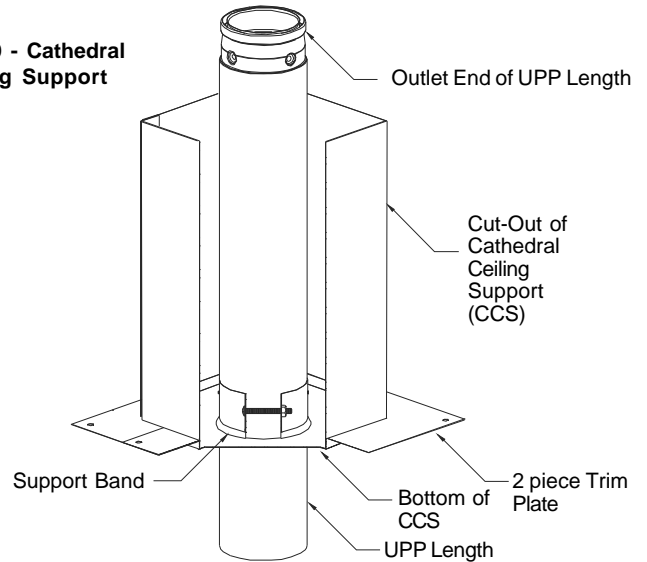

**SUPPORT BAND - Used with CSB, FCS and CCS**

The Support Band is used to secure the vent pipe to the plate on all 3 Ceiling Supports; CSB, FCS and CCS ( see Fig. 20).

**To Install:**

Slide the Support Band over the pipe with the flanged edge to the bottom to make contact with the Ceiling Support plate (see Figs 17, 18 & 19). Slide pipe through the hole of the ceiling support to determine and mark proper elevation of pipe. Remove pipe from the ceiling support. Using the elevation mark, locate and secure Support Band to pipe with nut and bolt, drawing tabs together. Insert 1/4" screws (provided) through pre-punched holes in the band and into the outer wall of the pipe to prevent any slip. Re-insert the assembly through ceiling support opening from above until Support Band(now attached to pipe) rests on the bottom of the ceiling support. Connect to the lower pipes from the appliance. Add lengths of pipe as appropriate from above.

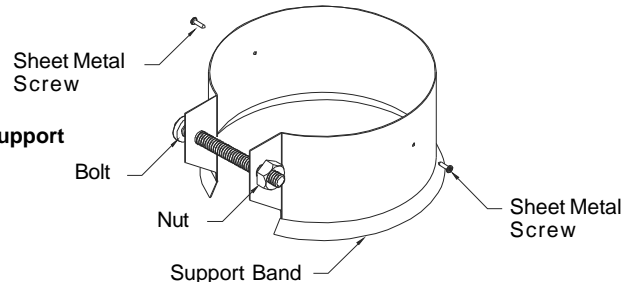

**Fig 20 - Support Band**

# ATTIC INSULATION SHIELD, ELBOWS, FLASHINGS AND VERTICAL TERMINATION

## ATTIC INSULATION SHIELD (UPP-AIS)

When Model UPP enters an open attic space, install an Attic Insulation Shield around the Pipe. The Attic Insulation Shield is to prevent any debris or blown-in insulation from coming in direct contact with the pipe. The Attic Insulation Shield has a two part cylinder (telescoping) which adjusts from 12-1/2" to 23-1/2". It also incorporates a lower joist shield (see Fig. 21). If it is not practical to use the AIS (due to height restriction), it is permissible to construct an enclosure with a 1" air space clearance to the outer pipe all the way to the underside of the roof deck. Install a Firestop (UPP-FS) on the ceiling side.

### To Install:

Slide the AIS over the pipe extending into the attic space and secure base plate on top of ceiling joist with nails or wood screws. Ensure the centering tabs are within the framed opening. Adjust the height of the shield to the desired height by sliding the top portion over the bottom one. Secure together the two portions with 2 sheet metal screws. The shields can be trimmed down to ensure fit in a low clearance area in the attic at the soffit end. Ensure the top of the shield is above the level of insulation. The lower joist shield will extend below the ceiling joist or sit inside of the Ceiling Support or the Cathedral Ceiling Support.

NOTE: It is permissible to add Universal Insulation Shielding (SUSI) to reduce cold air infiltration into the dwelling. See instructions supplied with the Universal Insulation Shielding.

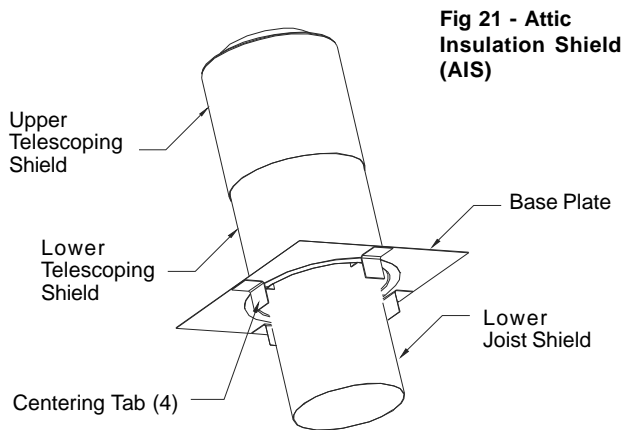

Fig 21 - Attic Insulation Shield (AIS)

## ELBOWS (UPP-90E, UPP-45E)

Model UPP provides 2 types of elbows, 45° and 90° (see Figs. 22 & 23). These are used to accommodate unusual offsets and configurations. The elbows are designed with the same end couplings as the straight sections in order to facilitate their use anywhere in the system. NOTE: Elbows are NOT adjustable. When offsets are necessary, adequate support above and below the elbows is required (see section 13).

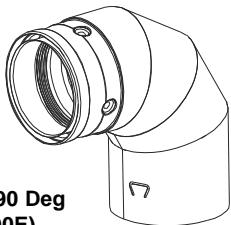

Fig 22 - 90 Deg Elbow (90E)

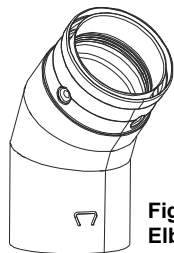

Fig 23 - 45 Deg Elbow (45E)

## ROOF FLASHINGS - TALL CONE (UPP-TF), ADJ (UPP-F6, UPP-F12)

Roof flashings are used to provide a transition at the roof through which the vent will pass and to protect the interior of the structure from weather (see Fig. 24). The UPP-TF is intended for use only on flat roofs while the UPP-F6 and F12 are designed for use on roofs having a slope of 1/12 - 6/12 and 6/12 - 12/12. Flashings are always used in conjunction with a storm collar (UPP-SC).

### To install:

After determining the exact location where the vent assembly will penetrate the roof, cut a hole which will provide the required minimum airspace to roof and/ or framing members. After adding vent sections so the assembly extends up through and is centered within the prepared opening, seal the joint between the roof and the flashing with roofing tar or silicone. On a sloped roof, place the flashing under the upper shingles and on top of the lower shingles - about half of the flashing should be under the shingles. Secure the flashing to the roof using roofing nails or roofing screws. Place some silicone on the UPP pipe protruding through the roof just above where the storm collar will be installed. On a flat roof, use silicone around the perimeter of the bottom side, set on roof and nail or screw at the corners. Apply silicone over the heads of the fasteners and an additional bead around the edge.

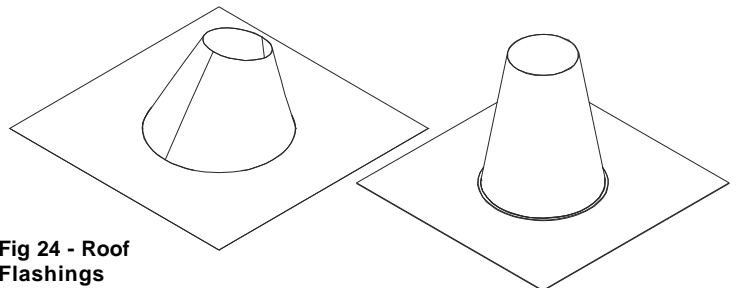

Fig 24 - Roof Flashings

## STORM COLLAR (UPP-SC)

The storm collar is used at the top of each flashing to assist in shedding water from the assembly. **To Install:** Prior to installing the cap and after installing the flashing, install the storm collar by sliding it down over the upper vent section downward into the silicone. Tighten the hose clamp (see Fig. 25) and apply a bead of silicone along the line where the storm collar meets the vent to ensure a watertight seal.

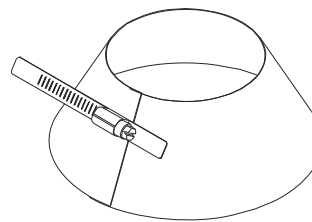

Fig 25 - Storm Collar (SC)

## VERTICAL TERMINATION CAP (UPP-VC)

The UPP-VC is intended for use in all installations in which the vent terminates in a vertical orientation (see Fig. 26). The cap provides necessary protection of the vent system from rain and other elements.

### To Install:

Simply push the cap down onto the top section of vent until fully engaged. The Locktab is then depressed (with thumb or blunt object) into the lock channel of the male end.

TERMINATION HEIGHT ABOVE ROOF - The termination of Model UPP should be located a sufficient distance from the roof so that the discharge opening is at least two (2) feet above the roof surface, or nearby structure.

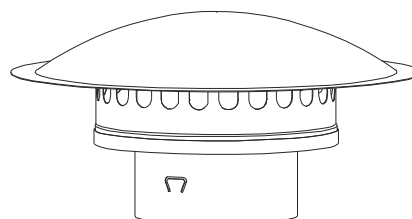

Fig 26 - Vertical Termination(VC)

# HORIZONTAL TERMINATIONS & CHIMNEY ADAPTER

## HORIZONTAL TERMINATION CAP (UPP-HC)

The horizontal termination cap (see Fig. 27) is designed specifically for use on installations in which the vent terminates in a horizontal orientation on the outside of a structure. See Fig.4 and the section which discusses this type installation.

**To Install:** Slide the cap onto the section of vent extending out from the wall (minimum 6") until fully engaged in the horizontal section of vent. The Locktab is then depressed (with thumb or blunt object) into the lock channel of the male end. Orient the cap so the exhaust end (openings) faces downward. NOTE - In order for the cap to provide the intended protection and vent the products of combustion properly, the cap must be installed in the above described orientation.

The above part descriptions and installation instructions should be referenced as you plan and install your particular installation. NOTE: The horizontal portion of the system beyond the vertical wall must be 6" minimum of vent length before adding the Horizontal Termination.

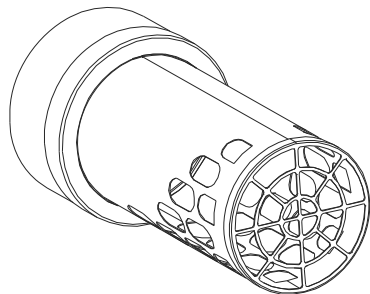

Fig 27 - Horizontal Termination (HC)

## SCREEN CAP (UPP-45T)

As an alternate to the Horizontal Termination, a 45 Degree Elbow in conjunction with the Screen Cap (see Fig. 28) can be used for an Horizontal Termination Cap. This design will direct flue gases away from the wall and increase their velocity, projecting them further away from the building.

Note: When using the 45 Degree Elbow and the Screen Cap, make sure it will be installed so that the hot flue gases do not overheat any of the surrounding area or pose any burn hazard to humans.

### To Install:

Slide the 45 Degree Elbow onto the section of vent extending out from the wall (minimum 6") until fully engaged in the horizontal section of vent. Ensure the outlet end of the 45 Degree Elbow is facing down. The Locktab is then depressed (with thumb or blunt object) into the lock channel of the male end. Install the Screen Cap in the same manner. NOTE - In order for this type of termination to provide the intended protection and vent the products of combustion properly, it must be installed in the above described orientation.

The above part descriptions and installation instructions should be referenced as you plan and install your particular installation. NOTE: The horizontal portion of the system beyond the vertical wall must be 6" minimum of vent length before adding the 45 Degree Elbow and Screen Cap.

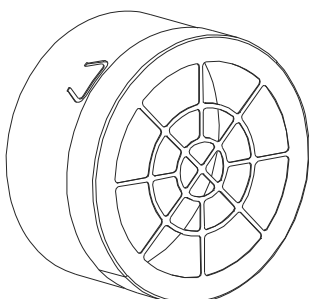

Fig 28 - Screen Cap (45T)

## CHIMNEY ADAPTER (UPP-CA6, CA8) - USA

If it is intended to connect UPP to an existing Type A Chimney System (UL103HT):

A. Ensure the existing Type A chimney is clean, code compliant and inspected for structural integrity.

B. Reference the appliance manufacturer's installation instructions to determine if this type of connection is permissible. Follow local installation codes. In Canada this type of connection is not permissible, the existing chimney must be listed to ULC-S629 (2100 chimney) and must be relined.

C. Remove existing black connector pipe, leaving the existing Type A chimney and the Stove Pipe Adapter in place.

D. Install the correct sized Chimney Adapter (CA6 or CA8) on the outside of the existing Type A Stove Pipe Adapter. Mark and drill a minimum of three (3) 1/8" diameter holes (equally spaced around the perimeter and approximately 1/2" beneath the top of the UPP-CA) through the Stove Pipe Adapter. Secure in place with 3 #8 x 1/2" sheet metal screws through holes. See Fig.29.

E. Connect the appropriate Appliance Adapter to the appliance flue outlet with high temperature silicone sealant. Secure in place by tightening the hose clamp. Install pipe lengths and connect to the Chimney Adapter.

Fig 29 - US Chimney Adapter (CA)

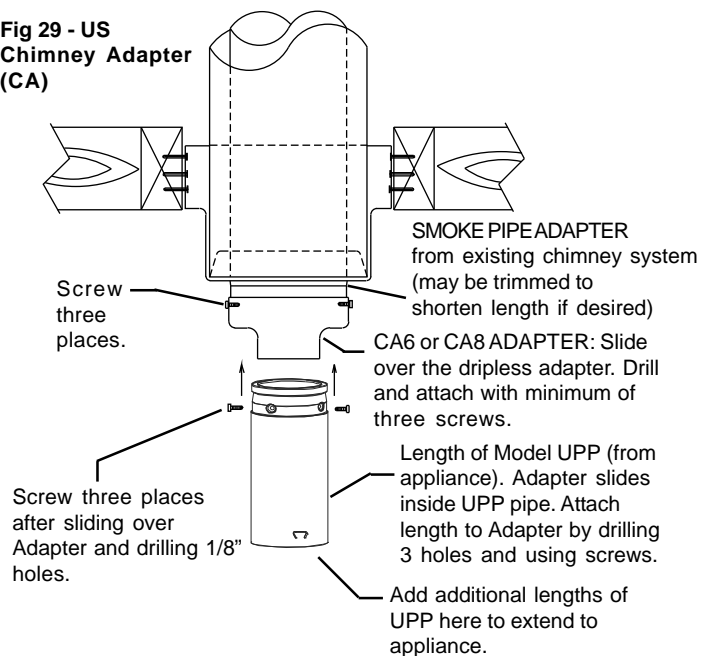

NOTE: Appliances always function better when the chimney is fully relined. Venting a pellet fueled appliance into an existing oversized chimney may result in a significant slow down in the flow of products of combustion where the vent size increase occurs. This may have an impact upon the operation of the appliance and may result in increased amounts of fine, powdery dust accumulations and/or condensation occurring within the vent system. If such installation is necessary, additional precaution should be taken to check the operation of the appliance and dust accumulation. More frequent cleaning may be necessary. It is highly recommended to fully reline the Type A chimney system (UL103HT or ULC-S629) with UPP Pellet Pipe. You can also reline using a stainless steel flexible or rigid liner (listed to UL1777 or CAN/ULC-S635). You will need to use the Reverse Flex Connector (UPP-FCR).

# MASONRY ADAPTER & MASONRY FIREPLACE

## MASONRY ADAPTER (UPP-MA)

Check with your local authority having jurisdiction as regulations are different in Canada and the USA for this application. In Canada the masonry chimney must be relined with a Listed stainless steel rigid or flexible liner (listed to CAN/ULC-S635).

- Read the appliance manufacturer's installation instructions to ensure this type of installation is permitted or if any restrictions do exist such as a minimum diameter. The masonry chimney may exceed the recommended maximum height, check the suggested equivalent vent length provided by the manufacturer.

- Clean the existing masonry chimney so it is free of soot and creosote. Ensure the existing masonry chimney is clean, code compliant and inspected for structural integrity. Make any repairs necessary prior to relining.

### To Install - Side of Masonry Chimney:

1. Measure the overall height of the masonry chimney from top to the opening. Add 12" to ensure the Vertical Termination Cap will be above the crown of the chimney if relining completely with UPP.

2. Measure the length of the horizontal breach as you will need to connect the Masonry Adapter to the Tee snout of the Stainless Steel liner. Fasten the Tee snout to the Masonry Adapter with 3 stainless steel sheet metal screws and high temperature silicone.

3. Insert the assembly through the opening until the Masonry Adapter fits flush to the wall of the chimney. If the Masonry Adapter is too long and does not fit flush to the wall, or it projects too far in the Tee branch, the Adapter should be trimmed for proper fit. If the Adapter is loose fitting or gaps are present when it is installed the gaps should be filled with a suitable filler such as a high temperature refractory cement. Read the installation instructions supplied with the stainless steel liner system. NOTE: Apply silicone to all liner connections including the Masonry Adapter.

4. Assemble all necessary UPP components you will need from the back of the appliance to reach the Masonry Adapter. You may need an Adjustable Length.

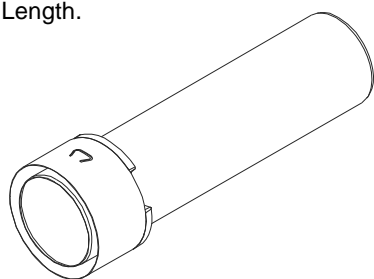

Fig 30 - Masonry Adapter (MA)

### To Install - Masonry Fireplace: (See Figure 31)

Measure the overall height of the masonry chimney from top to the UPP-Tee at the back of the pellet insert.

Read the appliance manufacturer's installation instructions to ensure this type of installation is permitted or if any restrictions do exist such as a minimum diameter. The masonry chimney may exceed the recommended maximum height, check the suggested equivalent vent length. Two Insert Flex Kits are available (see Kits for Pellet Pipe Section).

NOTE: A Reverse Flex Connector (UPP-FCR) is supplied in the Flex Kit to connect the flex to the UPP Tee. A bead of silicone will need to be applied to seal the connection. Same at the Flashing Adapter.

Assemble all necessary UPP components you will need from the back of the appliance to reach the stainless steel liner.

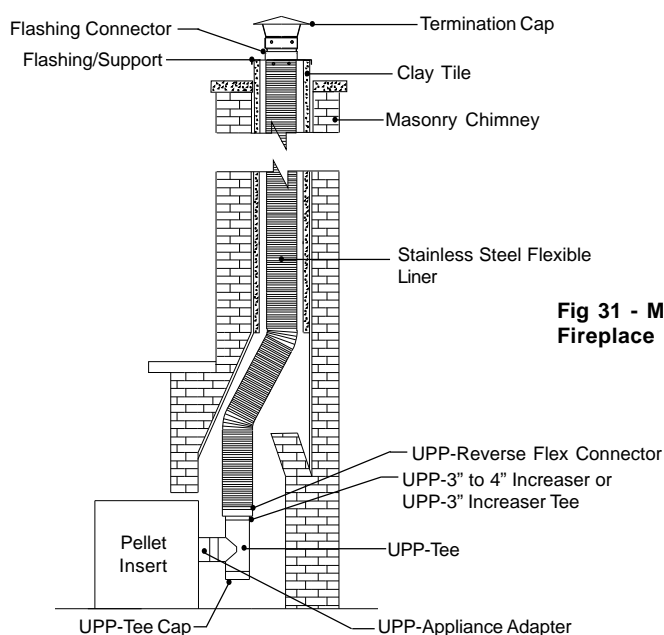

Fig 31 - Masonry Fireplace Reline

## 15. PAINTING

To prolong the life and appearance of the outer casing and other parts of Model UPP Vent System located outdoors, use proper painting procedure at time of installation. Remove oil and dirt with a solvent such as a degreaser. Paint first with a good quality zinc primer or other primer recommended for use on galvalume steel. Next apply an appropriate finish coat. Similar considerations apply for painting of internal components, for aesthetic purposes.

Ordinary house paints applied directly to outer casing may not adhere well and do not prevent under film corrosion which leads to paint loosening and peeling. Be sure to use a good primer undercoat and an appropriate finish coat.

## 16. MAINTENANCE REQUIREMENTS

Refer to the appliance manufacturer's maintenance instructions for recommendations relative to required maintenance of your appliance.

-Model UPP vent system requires periodic inspection and cleaning with an appropriately sized brush which will not scratch the inside surface of the flue. DO NOT USE chemical cleaners to clean your venting system.

Frequency of necessary vent system cleaning will vary with the appliance, vent system configuration and climate. Certain wood pellet burning appliances may give off more fine dust than others.

-In any case it is recommended that the complete assembly be inspected and cleaned (if any buildup has occurred) at the beginning of each heating season and at least monthly thereafter to determine if ash or soot has built up. When a maximum of 1/4" thickness of build-up has accumulated, it needs to be removed to reduce the risk of a chimney fire.

-TO INSPECT AND CLEAN . . . Remove the termination cap or/and the Tee Cap by prying the Lock-Tab with a flathead screwdriver and pulling until it disengages from the vent. Inspect system. If necessary clean by running a brush through the system several times in each direction. NOTE - Be sure that tee and termination caps are reinstalled and secured when Inspection/ Cleaning is completed and before the system is put back in use.

-IN CASE OF FIRE . . . If a fire occurred within the vent system, de-energize the appliance, close all draft controls, evacuate the premises and call the Fire Department. Do not use the appliance or vent system until they have been inspected by a qualified individual and declared suitable for further use.

# UPP SYSTEM PARTS

## MODEL UPP SYSTEM PARTS

PART	DESCRIPTION
UPP-60	.....60" Length
UPP-60B	.....60" Length - Black
UPP-36	.....36" Length
UPP-36B	.....36" Length - Black
UPP-24	.....24" Length
UPP-24B	.....24" Length - Black
UPP-18	.....18" Length
UPP-18B	.....18" Length - Black
UPP-12	.....12" Length
UPP-12B	.....12" Length - Black
UPP-06	.....6" Length
UPP-06B	.....6" Length - Black
UPP-ADJ12	.....12" Adjustable Length
UPP - ADJ12B	.....12" Adjustable Length - Black
UPP-45E	.....45Deg Elbow
UPP-45EB	.....45Deg Elbow - Black
UPP-90E	.....90Deg Elbow
UPP-90EB	.....90Deg Elbow - Black
UPP-T	.....Tee w/Tee Cap
UPP-TB	.....Tee w/Tee Cap - Black
UPP-DT	.....Double Tee w/Tee Caps
UPP-DTB	.....Double Tee w/Tee Caps - Black
UPP-TA	.....Tee & Cap w/ Appliance Adapter
UPP-TAB	.....Tee & Cap w/Appliance Adapter - Black
UPP-IT	.....In increaser Tee & Cap
UPP-ITB	.....In increaser Tee & Cap - Black
UPP-TC	.....Tee Cap
UPP-TCB	.....Tee Cap - Black
UPP-VCC	.....Vacuum Cleanout Cap
UPP-CSB	.....Ceiling Support - Black
UPP-FCS	.....Firestop Ceiling Support

## MODEL UPP SYSTEM PARTS

PART	DESCRIPTION
UPP-CCS	.....Cathedral Ceiling Support - Black
UPP-WB	.....Wall Band / Support
UPP-AA	.....Appliance Adapter
UPP-AAB	.....Appliance Adapter - Black
UPP-HAA1	.....Harman Appliance Adapter - Outside
UPP-HAA2	.....Harman Appliance Adapter - Inside
UPP-DTA	.....DT Adapter
UPP-WTB	.....Wall Thimble - Black
UPP-FS	.....Firestop
UPP-AIS	.....Attic Insulation Shield
UPP-TP	.....Trim Plate - Black
UPP-HC	.....Horizontal Termination Cap
UPP-VC	.....Vertical Termination Cap
UPP-45T	.....Screen Cap
UPP-FC	.....Flex Connector
UPP-FCR	.....Reverse Flex Connector
UPP-MA	.....Masonry Adapter
UPP-CA6	.....US Chimney Adapter - 6"
UPP-CA8	.....US Chimney Adapter - 8"
UPP-I4	.....In creaser - 3" to 4"
UPP-I4B	.....In creaser - 3" to 4" - Black
UPP-SC	.....Storm Collar
UPP-TF	.....Tall Cone Roof Flashing
UPP-F6	.....Adjustable Roof Flashing 0/12 - 6/12
UPP-F12	.....Adjustable Roof Flashing 6/12 - 12/12
UPP-IK25	.....In sert Flex Kit 25'
UPP-IK35	.....In sert Flex Kit 35'
UPP-TWK	.....Thru The Wall Kit
UPP-BK	.....Basement Kit
7001SIL	.....Dielectric Grease - 5.3 oz
GE605-3A	.....Replacement 3" Silicone Gasket
GE605-4A	.....Replacement 4" Silicone Gasket

## KITS FOR UPP PELLET PIPE

Refer to each component found in these instructions for their installation. For an Insert Kit installation, read the appliance manufacturer's installation instructions to ensure this type of installation is permitted or if any restrictions do exist such as a minimum diameter. See the Masonry Fireplace section.

PART	DESCRIPTION	CONTENTS
4UPP - IK25	.....Insert Flex Kit - 25 ft	4" x 25 feet of Stainless Steel Flex Liner, 3" and 4" Appliance Adapters, 3" to 4" In creaser, Tee and Tee Cap, Reverse Flex Connector, Vertical Termination Cap, Flat Flashing, Flashing Adapter and Silicone Sealant.
4UPP - IK35	.....Insert Flex Kit - 35 ft	4" x 35 feet of Stainless Steel Flex Liner, 3" and 4" Appliance Adapters, 3" to 4" In creaser, Tee and Tee Cap, Reverse Flex Connector, Vertical Termination Cap, Flat Flashing, Flashing Adapter and Silicone Sealant.
3UPP - TWK	.....Through the Wall Kit - 3 in	3" Appliance Adapter, 5 x 12" Lengths, 90° Elbow, Tee and Tee Cap, Wall Thimble, 2 Wall Band/Supports, Horizontal Termination Cap. NOTE: 4" Appliance Adapter and 3" to 4" In creaser included in the 4" Kit.
4UPP - TWK	.....Through the Wall Kit - 4 in	
4UPP - BK	.....Basement Kit - 4 in	3" and 4" Appliance Adapters, 3" to 4" In creaser, 2 x 12" Lengths, 4 x 24" Lengths, 2 4" Tees and Tee Caps, 2x 4" 90's, Wall Thimble, 2 Wall Band/Supports, Horizontal Termination.

5030 Corporate Exchange Blvd. SE  
Grand Rapids, MI 49512  
Telephone: 800.433.6341

**Ultimate Pellet Pipe**  
[www.UltimatePelletPipe.com](http://www.UltimatePelletPipe.com)

P.O. Box 526, Depot 1,  
Hamilton, ON L8L 7X6  
Telephone: 888.735.5475

# INSTALLATION INFORMATION

Leave with homeowner. Homeowner: Keep in a safe place for future reference.

## **PRODUCT INFO**

VENT MODEL : **Ultimate Pellet Pipe**

FLUE SIZE \_\_\_\_\_

TOTAL HEIGHT \_\_\_\_\_

INSIDE INSTALLATION  OUTSIDE INSTALLATION

CONNECTED TO (type of appliance):

- WOOD PELLET APPLIANCE
- WOOD PELLET BOILER
- WOOD PELLET INSERT
- WOOD PELLET FURNACE
- OTHER (specify) \_\_\_\_\_

LOCATION OF APPLIANCE:

- BASEMENT
- MAIN FLOOR
- OTHER (specify) \_\_\_\_\_

INSTALLATION DATE: \_\_\_\_\_

## **DEALER INFO**

DEALER NAME: \_\_\_\_\_

Address: \_\_\_\_\_

City: \_\_\_\_\_

Province/State: \_\_\_\_\_

## **TECHNICIAN INFO**

TECHNICIAN NAME: \_\_\_\_\_

Address: \_\_\_\_\_

City: \_\_\_\_\_

Province/State: \_\_\_\_\_